

PARTS LIST						
ITEM	QTY	PART NO.	PART DESCRIPTION	LENGTH	UNIT WT.	NET WT.
1	1	X-156478-BP	1/2" FLAT PLATE (A36)	8 1/2 in	10.05	10.05
2	4	G58R-12	5/8" x 12" THREADED ROD (HDG.)		1.05	4.18
3	8	G58FW	5/8" HDG USS FLATWASHER	1/8 in	0.07	0.56
4	8	G58LW	5/8" HDG LOCKWASHER		0.03	0.21
5	8	G58NUT	5/8" HDG HEAVY 2H HEX NUT		0.13	1.04
					TOTAL WT. #	16.04

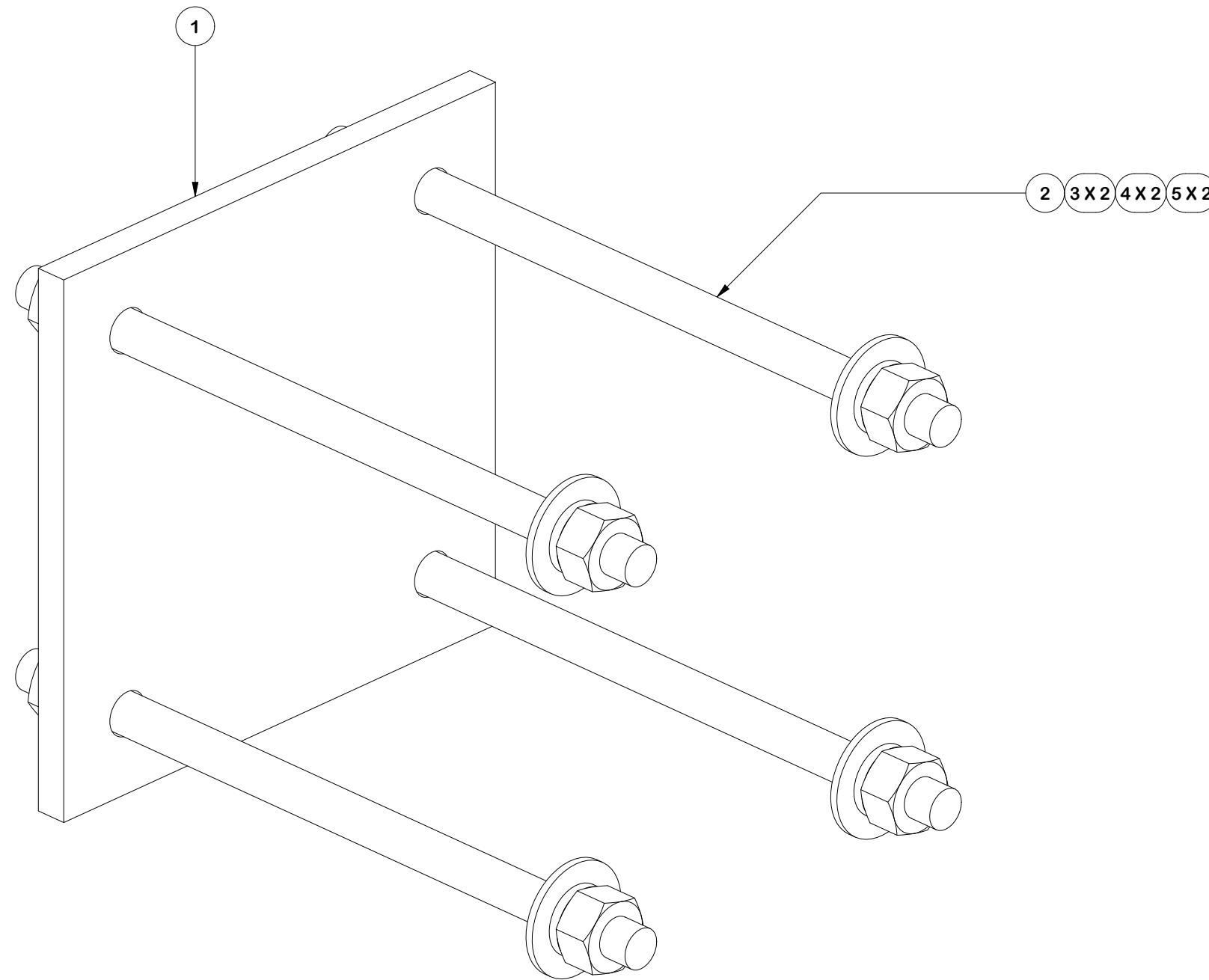

NOTE:
COMPATIBLE WITH 6" X 6" HOLE PATTERNS

FINISH:
HOT DIP GALVANIZED.

TOLERANCE NOTES

TOLERANCES ON DIMENSIONS, UNLESS OTHERWISE NOTED ARE:
 SAWED, SHEARED AND GAS CUT EDGES ($\pm 0.030"$)
 DRILLED AND GAS CUT HOLES ($\pm 0.030"$) - NO CONING OF HOLES
 LASER CUT EDGES AND HOLES ($\pm 0.010"$) - NO CONING OF HOLES
 BENDS AND ANGLES ARE $\pm 1/2$ DEGREE
 ALL OTHER MACHINING ($\pm 0.030"$)
 ALL OTHER ASSEMBLY ($\pm 0.060"$)

PROPRIETARY NOTE:
 THE DATA AND TECHNIQUES CONTAINED IN THIS DRAWING ARE PROPRIETARY INFORMATION OF VALMONT INDUSTRIES AND CONSIDERED A TRADE SECRET. ANY USE OR DISCLOSURE WITHOUT THE CONSENT OF VALMONT INDUSTRIES IS STRICTLY PROHIBITED.

DESCRIPTION
**5/8" HOLLOW WALL MOUNT KIT
 W/ SOLID BACKING PLATE**

SITE PRO 1
 A valmont COMPANY
 Engineering Support Team:
1-888-753-7446

CPD NO. DRAWN BY ENG. APPROVAL
CMFL 9/21/2023

PART NO.
HWK58-HD

CLASS SUB DRAWING USAGE CHECKED BY
87 02 CUSTOMER

DWG. NO.
HWK58-HD